

TO-220-3L Plastic-Encapsulate MOSFETS

FEATURES

- Low Crss
- Fast Switching
- 100% avalanche tested
- N-Channel Power MOSFET

MECHANICAL DATA

- Case style: TO-220-3L molded plastic
- Mounting position: any

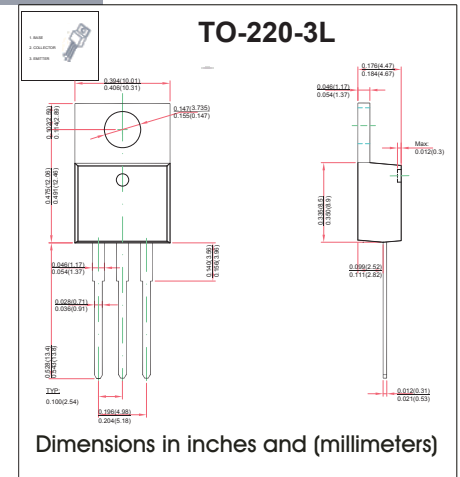

MAXIMUM RATINGS AND CHARACTERISTICS

@ 25°C Ambient Temperature (unless otherwise noted)

Parameter	Symbol	Value	Unit
Drain-Source Voltage	V_{DS}	600	V
Gate-Source Voltage	V_{GS}	± 30	
Continuous Drain Current	I_D	10	A
Power Dissipation	P_D	2	W
Thermal Resistance from Junction to Ambient	$R_{\theta JA}$	62.5	$^{\circ}C/W$
Junction Temperature	T_J	150	$^{\circ}C$
Storage Temperature	T_{stg}	-50 ~ +150	

MOSFET ELECTRICAL CHARACTERISTICS $T_A=25^{\circ}C$ unless otherwise specified

Parameter	Symbol	Test Condition	Min	Typ	Max	Unit
Drain-Source Breakdown Voltage	$V_{(BR)DSS}$	$V_{GS} = 0V, I_D = 250\mu A$	600			V
Gate-Threshold Voltage (note1)	$V_{GS(th)}$	$V_{DS} = V_{GS}, I_D = 250\mu A$	2.0		4.0	
Gate-Body Leakage Current (note1)	I_{GSS}	$V_{DS} = 0V, V_{GS} = \pm 30V$			± 100	nA
Zero Gate Voltage Drain Current	I_{DSS}	$V_{DS} = 600V, V_{GS} = 0V$			10	μA
Drain-Source On-State Resistance (note1)	$R_{DS(on)}$	$V_{GS} = 10V, I_D = 5A$			1	Ω
Input Capacitance	C_{iss}	$V_{DS} = 25V, V_{GS} = 0V,$ $f = 1MHz$		1430		pF
Output Capacitance	C_{oss}				117	
Reverse Transfer Capacitance	C_{rss}				2.2	
Turn-On Delay Time	$t_{d(on)}$	$V_{DD} = 325V, I_D = 10A,$ $R_G = 25\Omega$		46		ns
Rise Time	t_r			74		
Turn-Off Delay Time	$t_{d(off)}$			340		
Fall Time	t_f			66		
Forward on Voltage(note1)	V_{SD}	$V_{GS} = 0V, I_S = 10A$			1.4	V

Notes:

1. Pulse Test : Pulse Width $\leq 300\mu s$, Duty Cycle $\leq 2\%$.

Typical Characteristics

